

Beacon Hall Archive – Solhaven Annex Design – May 2023

The basic theme for our proposed annex in Solhaven is a lighthouse on an estuary in Marstown, somewhat nearby Glok's Pier as a callback to River's Rest.

We submitted an initial proposal for pre-approval in May of 2021 and were informed that the lighthouse concept was acceptable, but the layout and location were not exactly suitable.

We therefore propose a new layout and location for our lighthouse.



Figure 1: An estuary

GM feedback on initial proposal

After investigating the area for the room you requested [Marstown, Land's End], we feel that it doesn't quite fit for there to be a pier extending out from that. This is where the platform portion of Marstown touches down onto land. If you want to move south of here, there is a pier where the water becomes deep enough.

The building being a lighthouse is fine, but if it's to be at all functional, the location is not a good fit. Where it's proposed is basically near where the Cairnfang River pours down into Solhaven Bay. The ocean itself is more south and west of this Marstown location. Since a lighthouse is a jutting out point to avoid land, I don't think we'd find a lighthouse here in this area.

The estuary idea is fine, however the sea cave in this area may not be warranted. Marstown is not really rocky. It's muddy and marshy, with the area built on platforms.

In scanning the area for a better fit for your proposed plans, we didn't really come up with a room better suited around Land's End that hits all your marks. Alternatively, we could have a path leading from that room to the building (lighthouse or otherwise). And then rather than having the estuary in the waters of the marsh/bay, have something that is say north of the building be a pool of water that could be used as a swimming hole. And then beyond that could be a small cave, not necessarily a sea cave, but that would more be where there is solid land to have something like a cave.

New Proposed Location

Our initial proposed location for the entry room was [Marstown, Land's End], but we chose this room primarily as it was the first room outside of justice that came close to our preferred location near the estuary. After discussion with the GMs, it was confirmed that a house annex is always outside of justice, so we propose to build in the room just to the south or our original suggested location:

[Marstown, Shoreline - 1274]

As the raised platform approaches the Cairnfang river, less and less stable soil is available to support the buildings and inhabitants of Marstown. Rafts of large barrels have been tied together and serve as flotation for the walkway and the squat wooden buildings that line either side. A breathtaking and living display of color takes place in the waters to the southeast as the crystal waters of the Cairnfang mingle with the bluer waters of Solhaven Bay.

You also see Langi's pier to the southeast.

Obvious paths: north, southwest

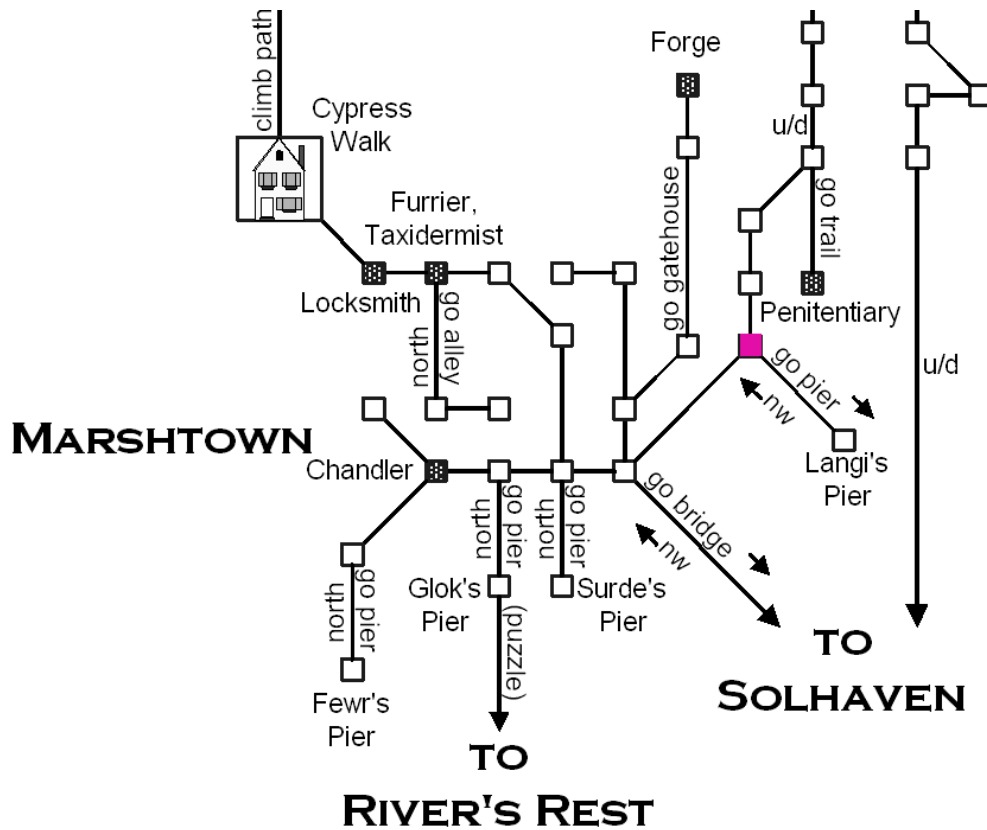

Figure 2: Tsoran map of Marstown Area. Proposed location for the annex entry room is highlighted in dark pink.

New Proposed Layout

The original proposed layout included a sea cave, which was considered unsuitable due to the muddy nature of the ground in Marsh town, so we have removed it from the new submission. Furthermore, we decided to lean into the idea of lighthouse jutting into the bay with our new layout.

The entry room would be accessed by a path leading to the shore of the estuary from under Langi's dock. Then one would proceed onto a jetty that would lead to the lighthouse at its end. The lighthouse would be members-only and contain three rooms. On the ground floor there would be an entry room with a spiral staircase providing access to the upper floor and a curtain (or door) to the lightkeeper's room (containing the lockers). From the top of the lighthouse, we would like to be able to add an orb like we have in the main house that allows us to look around (and maybe also peer out the windows or something to admire the surroundings).

Overview

- Entry is a path leading under Langi's dock to estuary
- Estuary (swimming hole)
- Jetty (fishing pond)
- Lighthouse
 - Main floor: entry with artifacts (peer from windows)
 - Main floor: lighthouse keeper's room (lockers)
 - Top of the Lighthouse: orb to peer around?

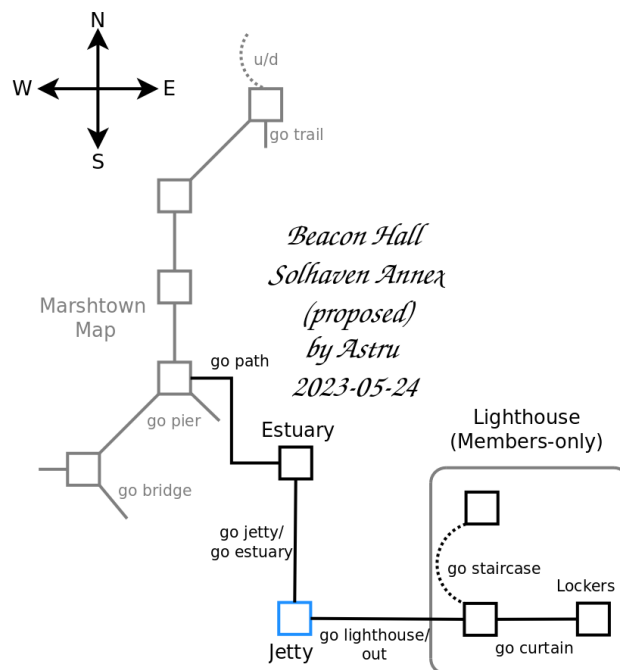

Figure 3: Proposed annex layout